

ATTACHMENT CONVERTER KNX-308-72-DRI-LL-IN

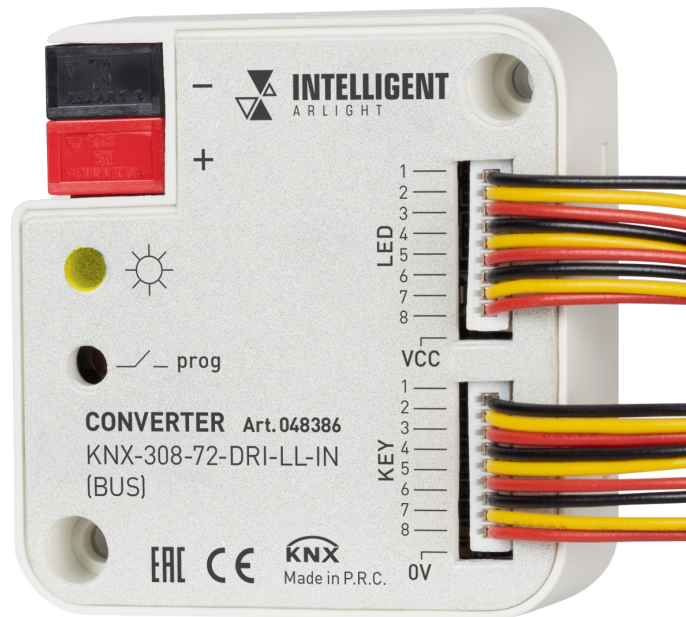

CONTENTS

1. SUMMARY	2
2. TECHNICAL PARAMETER, DIMENSION, AND WIRING DIAGRAM	2
2.1. TECHNICAL PARAMETER	2
2.2. DIMENSION	2
2.3. WIRING DIAGRAM	2
3. ETS PARAMETER SETTING	3
3.1. PARAMETER WINDOW "INPUTX"	3
3.1.1. "SWITCH" FUNCTION	3
3.1.2. "SWITCH / DIMMING" FUNCTION	4
3.1.3. "VALUE / FORCE OUTPUT" FUNCTION	4
3.1.4. "SCENE CONTROL" FUNCTION	5
3.1.5. "SHUTTER CONTROL" FUNCTION	5
3.1.6. "SHIFT REGISTER" FUNCTION	6
3.2. PARAMETER WINDOW "LED"	6
4. DESCRIPTION OF COMMUNICATION OBJECT	7
4.1. "INPUT X" COMMUNICATION OBJECT	7
4.2. "LED" COMMUNICATION OBJECT	8

1. SUMMARY

Universal interfaces are mainly used in building control systems, installed as a system with other devices via the EIB/ KNX bus. They are functionally simple and intuitive to operate, allowing users to plan the appropriate control functions according to their needs.

The functional application of the universal interface is realized by ordinary buttons or switches, using binary technology for communication, mainly used to control actuator equipment, such as dimmers, relays, etc., and indirectly control various household appliances. At the same time, the universal interface can also be used to control LEDs.

The universal interface is connected directly to the bus via the EIB terminal block and does not require an additional supply voltage. The assignment of the physical address and the setting of the parameters can be done using the engineering tool software ETS with pr5 files (version ETS5 or higher). The functions of the module are summarized as follows:

Dry contact input scanning for connecting regular switch panels or sensors of the dry contact output type, up to 8, to intelligent control signals, all utilizing the functions outlined below:

- ▼ switching function
- ▼ dimmer function
- ▼ blinds function
- ▼ recall and store scene function
- ▼ fixed value send function
- ▼ shift register.

LED indication with up to 8 conventional LED indication output controls, capable of displaying the status of the lighting circuits to be displayed on the panel in real-time (the connected switch panel needs to be equipped with an LED indication connection), with a common cathode connection.

This manual provides the user with detailed technical information about the product, including installation and programming details, and explains how to use it with practical examples.

2. TECHNICAL PARAMETER, DIMENSION, AND WIRING DIAGRAM

2.1. TECHNICAL PARAMETER

APP	Max communication object group	Max group add	Max number of joint table
Universal Interface, 8-fold	32	80	80

2.2. DIMENSION

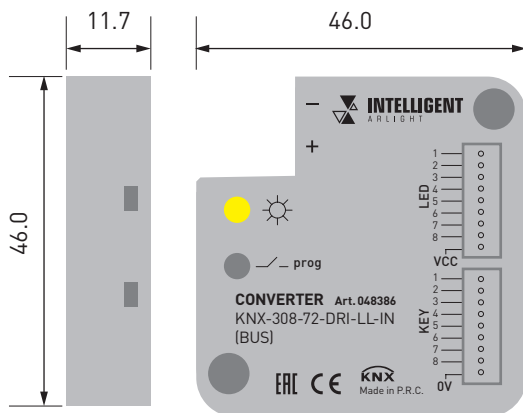

2.3. WIRING DIAGRAM

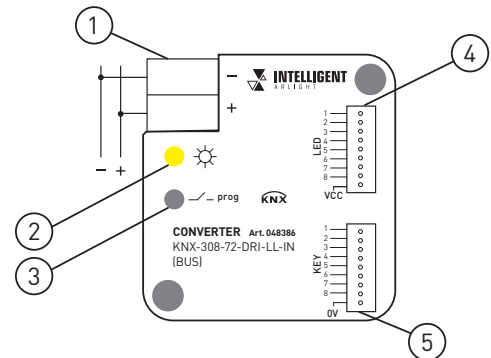
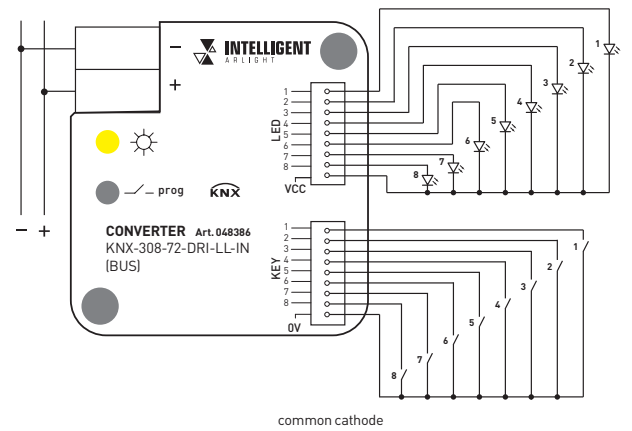
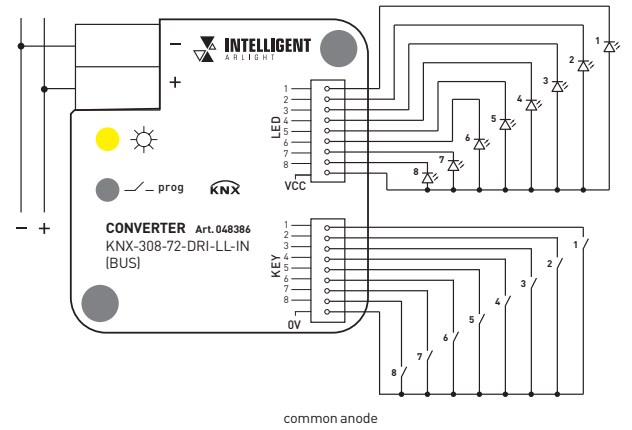

- ① KNX / EIB K-BUS Terminal
- ② Programming LED
- ③ Programming button
- ④ LED terminal
- ⑤ Dry contract terminal

3. ETS PARAMETER SETTING

The parameter in the ETS system is described in function blocks.

3.1. PARAMETER WINDOW "INPUTX"

This section describes the input functions in detail. There are 8 inputs in total, each with the same function, and one of them is used as an example:

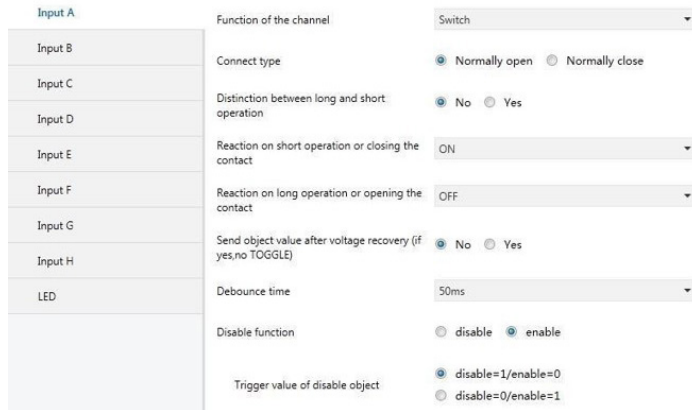

Figure3.1 "Input X-Switch"

Parameter "Function of the channel"

This parameter for setting the function of the input. If the option is "No function", it means that the function of this input is not enabled.

Options:

- No function
- Switch
- Switch/Dimming
- Value/Force output
- Scene control
- Shutter control

The following describes the specific parameter settings for each function.

3.1.1. "SWITCH" FUNCTION

"Switch" The parameter window is shown in Figure 4.1

"Connect type"

This parameter for setting the connect type for the contact. It is used to define whether the contact is a normally open contact or a normally close contact in general.

Options:

- Normally open
- Normally close

The parameters presented in this section are all in terms of Normally open types; Normally closed types operate oppositely to Normally open types.

"Distinction between long and short operation"

This parameter for setting whether the contact input distinguishes between long and short operations. If "yes" is selected, there is a waiting period after the opening/closing of the contact to determine whether the operation is long or short. Only then is a possible reaction triggered. The following drawing clarifies the function:

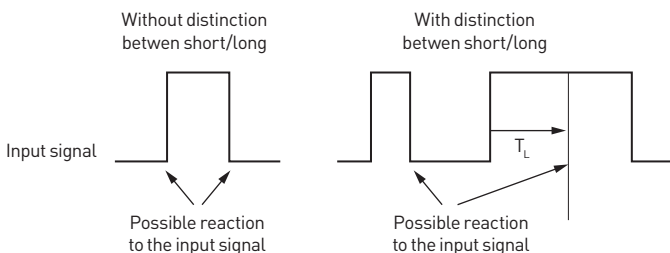

Options:

- Yes
- No

NOTE:

The processing of long operations in the following sections is the same as here. TL is the time for a long operation, the time required to determine that an input operation to be a long operation.

"Reaction on short operation or closing the contact"/ "Reaction on long operation or opening the contact"

This parameter for setting the operation to be performed when the contact is closed/broken or during long/short operation. The object value is updated as soon as the input is determined.

Options:

- No action
- ON
- OFF
- Toggle

"No action", no telegram sent

"ON", sends an on telegram;
"OFF", the off telegram is sent;
"Toggle", each action will toggle between switch ON and switch OFF, e.g., if last time a switch ON telegram was sent (or received), then this action will trigger a switch OFF telegram to be sent; when the switch is operated again a switch ON telegram will be sent and so on, so the switch always remembers its last state and will convert to another value when operated.

"Send object value after voltage recovery (if yes, no TOGGLE)"

This parameter for setting whether to send the current value of object "Switch" to the bus after bus voltage recovery. The parameter is visible if there is no distinction between a short and long operation.

Options:

- Yes
- No

If the parameter "Yes" is selected, it will send the current value on the bus. Only when the value "Toggle" has not been set in either of the two parameters "Reaction on short operation or closing the contact"/"Reaction on long operation or opening the contact", the value of the object can be sent on the bus. If one of the two parameters has the value "TOGGLE", no values are sent in general on the bus after bus voltage recovery. If "No reaction" is selected, there is no values are sent on the bus either.

"Long operation after (*0.1s)"

This parameter is visible when distinguishing between long/short operations. The period TL is defined here, after which an operation is interpreted as "long".

Options:

- 3...25

"Debounce time"

This parameter is for setting the debounce time to avoid the unnecessary operations which is caused by the contact triggered multiple times in bouncing time, debounce time is the valid time of the contact operation.

Options:

- 10ms/20ms/.../150ms

"Disable function"

This parameter for setting whether to enable the disable function of the input.

Options:

- Disable
- Enable

If "Enable", the input can be disabled or enable by the object.

"Trigger value of disable object"

This parameter for setting the trigger value for the disable/enable input.

Options:

- Disable=1/enable=0
- Enable=0/enable=1



3.1.2. "SWITCH / DIMMING" FUNCTION

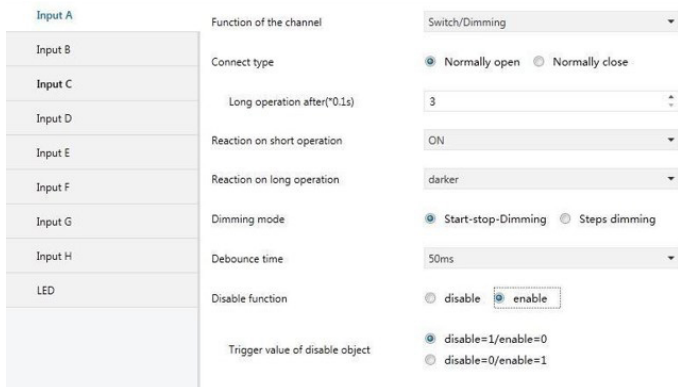

Figure 3.2. "Switch / Dimming" parameter setting window

"Connect type"

This parameter for setting the connect type for the contact. It is used to define whether the contact is a normally open contact or a normally close contact in general.

Options:
Normally open
Normally close

The parameters presented in this chapter are all in terms of Normally open types; Normally closed types operate oppositely to Normally open types.

"Long operation after (*0.1s)"

The period TL is defined here, after which an operation is interpreted as "long".

Options: 3...25

"Reaction on short operation"

This parameter for setting switch's value that is sent when inputting a short operation.

Options:
No action
ON
OFF
Toggle

"No action", no telegrams were sent. "ON", send the open telegram; "OFF", send the off telegram; "Toggle", each operation will toggle between switching on and off.

"Reaction on long operation"

This parameter for setting the value of the relative dimming that is sent when inputting a long operation, brighter or darker, and stops dimming when the button is released.

Options:
Brighter Darker Toggle

"Brighter", Sends a brighter telegram when the button is long operated. "Darker", Send a darker telegram. "Toggle", Each operation will switch between brighter and darker.

Note: In the parameter settings of the switch and relative dimming, if one of the options is "Toggle", there will be a linkage between them; For example, if the switching object receives an on state this time, the next time it will be darker when dimming. If it receives an off state, it will brighter when dimming.

"Dimming mode"

This parameter for setting the relative dimming method, whether the start-stop or the step-by-step dimming method.

Options:
Start-stop dimming
Steps-dimming

If you select the "Start-stop dimming" option, the relative dimming method is start-stop dimming; a dimming or brightening telegram is sent when dimming, and a stop telegram is sent when dimming is finished. In the start-stop dimming mode, the dimming telegram does not need to be sent cyclically. If you select the "Steps-dimming" option, the relative dimming mode is step-by-step dimming mode; the dimming telegram will be sent in a cycle, and the stop-dimming telegram will be sent immediately when the dimming is finished.

"Brightness change one very sent"

This parameter is visible when the "Dimming mode" options is "Steps dimming". It is for setting the brightness (in percentage) which can be changed by sending a dimming telegram cyclically.

Options:
100%
50%
...
1.56%

"Interval of Tele. Cyclic send [*0.1s, 0=send once]"

When the parameter "Dimming mode" is "Steps dimming", this parameter is visible. This parameter for setting the time interval for sending a dimming telegram cyclically.

Options: 0...25

"Debounce time"

This parameter is for setting the debounce time to avoid the unnecessary operations which is caused by the contact triggered multiple times in bouncing time, i.e., the minimum effective time for contact input.

Options: 10ms/20ms/.../150ms

"Disable function"

This parameter for setting whether to enable or disable the input

Options: Disable/Enable

If "Enable", the input can be disabled or enabled by the object.

"Trigger value of disable object"

This parameter for setting the trigger value for the disable/enable input.

Options:
Disable=1/enable=0
Enable=0/enable=1

3.1.3. "VALUE / FORCE OUTPUT" FUNCTION

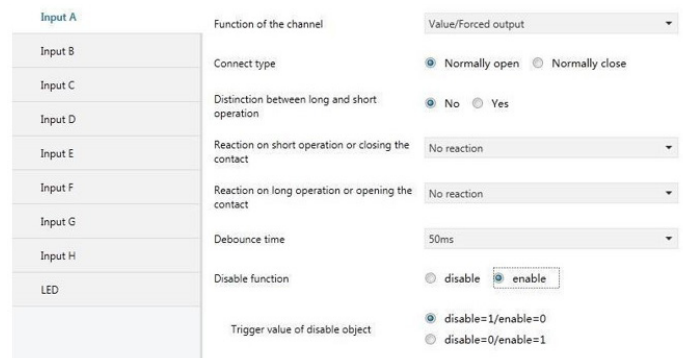

Fig.3.3. Parameter window "Input X-Value/Forced output"

"Connect type"

This parameter for setting the connect type for the contact. It is used to define whether the contact is a normally open contact or a normally close contact in general.

Options:
Normally open
Normally close

The parameters presented in this section are all in terms of Normally open types; Normally closed types operate oppositely to Normally open types.

"Distinction between long and short operation"

This parameter for setting whether the contact input distinguishes between long and short operations. If "yes" is selected, there is a waiting period after the opening/closing of the contact to determine whether the operation is long or short.

Options: yes/No

"Long operation after (*0.1s)"

This parameter is visible when distinguishing between long/short operations. The period TL is defined here, after which an operation is interpreted as "long".

Options: 3...25



“Reaction on short operation or closing the contact”/“Reaction on long operation or opening the contact”

This parameter for setting the type of data sent when the contact is closed/disconnected or during long/short operation.

- Options:
- No reaction
 - 1bit value[0/1]
 - ...
 - 2byte value[0...65535]

“Output value[...]”

This parameter for setting the value of the data sent when the operation is performed. The range of values depends on the data type selected in the previous parameter.

“Debounce time”

This parameter is for setting the debounce time to avoid the unnecessary operations which is caused by the contact triggered multiple times in bouncing time, i.e., the minimum practical time of the contact input.

- Options: 0ms/20ms/.../150ms

“Disable function”

This parameter for setting whether to enable the disable function of the input.

- Options: Disable/Enable

If “Enable”, the input can be disabled/enabled by the object.

“Trigger value of disable object”

This parameter for setting the trigger value for the disable/enable input.

- Options:
- Disable=1/enable=0
 - Enable=0/enable=1

3.1.4. “SCENE CONTROL” FUNCTION

“Scene control”parameter setting window shown as Fig.3.4

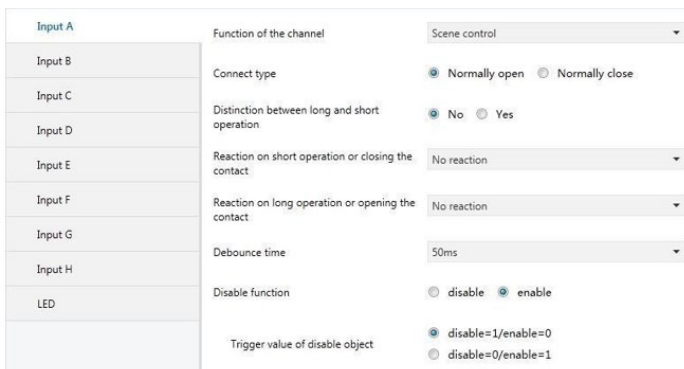

Fig. 3.4 Parameter setting window “Input X-Scene control”

“Connect type”

This parameter for setting the connect type for the contact. It is used to define whether the contact is a normally open contact or a normally close contact in general.

- Options:
- Normally open
 - Normally close

The parameters presented in this chapter are all in terms of Normally open types; Normally closed types operate in the opposite way to Normally open types.

“Distinction between long and short operation”

This parameter for setting whether the contact input distinguishes between long and short operations. If “yes” is selected, there is a waiting period after the opening/closing of the contact to determine whether the operation is long or short.

- Options: yes/No

“Long operation after (*0.1s)”

This parameter is visible when distinguishing between long/short operations. The period TL is defined here, after which an operation is interpreted as “long”.

- Options: 3...25

“Reaction on short operation or closing the contact”/“Reaction on long operation or opening the contact”

Scenes are set here to be recalled or stored when the contact is closed/disconnected or during long/short operations.

- Options:
- No reaction
 - Recall scene
 - Store scene

“Scene number (1..64)”

This parameter for setting the scene number, the scene number range: Scene NO.1~64, the corresponding telegram is 0~63

“Debounce time”

This parameter is for setting the debounce time to avoid the unnecessary operations which is caused by the contact triggered multiple times in bouncing time, debounce time is the valid time of the contact operation.

- Options: 10ms/20ms/.../150ms

“Disable function”

This parameter for setting whether to enable the disable function of the input.

- Options: Disable/Enable

If “Enable”, the input can be disabled or enabled by the object.

“Trigger value of disable object”

This parameter for setting the trigger value for disable/enable inputs.

- Options:
- Disable=1/enable=0
 - Enable=0/enable=1

3.1.5. “SHUTTER CONTROL” FUNCTION

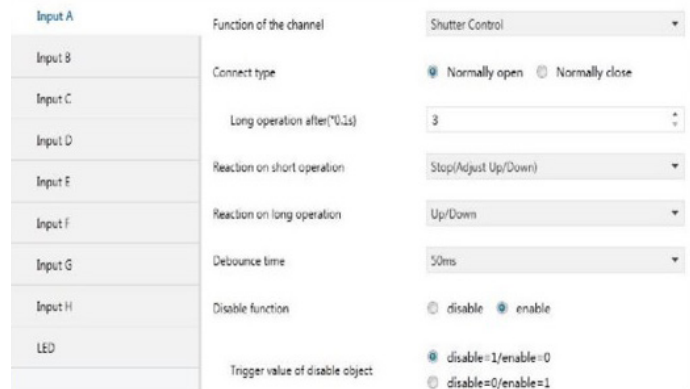

Fig.3.5. Parameter window “Input X-Shutter control”

“Connect type”

This parameter for setting the connect type for the contact. It is used to define whether the contact is a normally open contact or a normally close contact in general.

- Options:
- Normally open
 - Normally close

The parameters presented in this chapter are all in terms of Normally open types; Normally closed types operate in the opposite way to Normally open types.

“Long operation after (*0.1s)”

This parameter for setting the effective time for long operation. If the input contact connection time exceeds the time set here, the operation is determined to be a long operation; otherwise it is a short operation.

- Options: 3...25

“Reaction on short/long operation”

This parameter for setting the action to be performed when the input is a short or long operation

- Options:
- No action
 - Up Down
 - Up/Down
 - Stop(Adjust Up)
 - Stop(Adjust Down)
 - Stop(Adjust Up/Down)



“No action”, No action is performed
 “Up”, Raise or open the curtains;
 “Down”, down or close the curtain;
 “Up/Down”, Alternate the opening and closing of the curtain (up/down).
 “Stop(Adjust Up)”, Stop curtain running or adjust louver Angle;
 “Stop(Adjust Down)”, Stop curtain running or lower louver Angle;
 “Stop(Adjust Up/Down)”, Stop curtain running or alternate up/down louver angles.

“Interval of Tele. Cyclic send (*0.1s, 0=send once)”

This parameter is visible when the previous parameter options is “Stop...”. and this parameter for setting the time interval for cyclic sending of the louver angle adjustment message.

“Debounce time”

This parameter is for setting the debounce time to avoid the unnecessary operations which is caused by the contact triggered multiple times in bouncing time, debounce time is the valid time of the contact operation.

Options: 10ms/20ms/...../150ms

“Disable function”

This parameter for setting whether to enable or disable the input.

Options: Disable/Enable

If “Enable”,the input can be disabled or enabled by the object.

“Trigger value of disable object”

This parameter for setting the trigger value for disable/enable inputs

Options:
 Disable=1/enable=0
 Enable=0/enable=1

3.1.6. “SHIFT REGISTER” FUNCTION

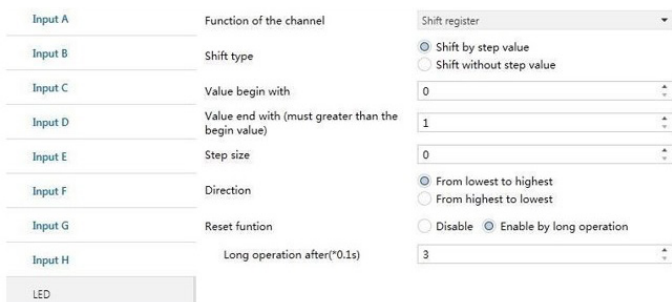

Figure 3.6. Parameter window “Input X- Shift register”

“Shift type”

This parameter for setting the shift type, whether it is with or without stepping values.

Options:
 Shift by step value
 Shift without step value

“Shift by step value”, with step value, you can set the start and end values of the shift and the value to be increased (from low to high direction) or decreased (from high to low direction) for each shift.

“Shift without step value”:when there is no step value, you can set the specific value that will be sent for each shift, up to 10 numbers, and one number will be sent for each operation.

“Value begin with”

This parameter is visible when “Shift by step value” is selected for the shift type and is used to set the begin value of the shift.

Options: 0...240

“Value end with (must greater than the begin value)”

This parameter is visible when “Shift by step value” is selected for the shift type and is used to set the end value of the Shift.

Options: 0...250

The end value must be greater than the start value.

“Step size”

This parameter is visible when “Shift by step value” is selected for the shift type, and is used to set the value that will be increased (low to high direction) or decreased (high to low direction) for each shift.

Options: 0...240

“Direction”

This parameter for setting the direction of the shift.

Options:
 From lowest to highest
 From highest to lowest

“From lowest to highest”, shift from low to high, e.g., from start value to end value, or from value 1 to value 10, and after reaching the end value or value 10, it will be reshift starting from the start value or value 1.

“From highest to lowest”, Shift from high to low, e.g., from end value to start value, or from value 10 to value 1, and after reaching the start value or value 1, it will be reshift starting from the end value or value 10.

“Reset function”

This parameter for setting whether to enable the shift reset function or not.

Options:
 Disable
 Enable by long operation

“Disable”

“Enable by long operation”, the shift is reset by a long operation, after which the shift will start again.

“Long operation after (*0.1s)”

This parameter is visible when the shift reset function is enabled, the period TL is defined here, after which an operation is interpreted as “long”.

Options: 3...25

3.2. PARAMETER WINDOW “LED”

This interface is used to set the function of the LED. 8 LEDs are provided for indication, each LED can be set individually, we will take one of the LEDs as an example for parameter setting.

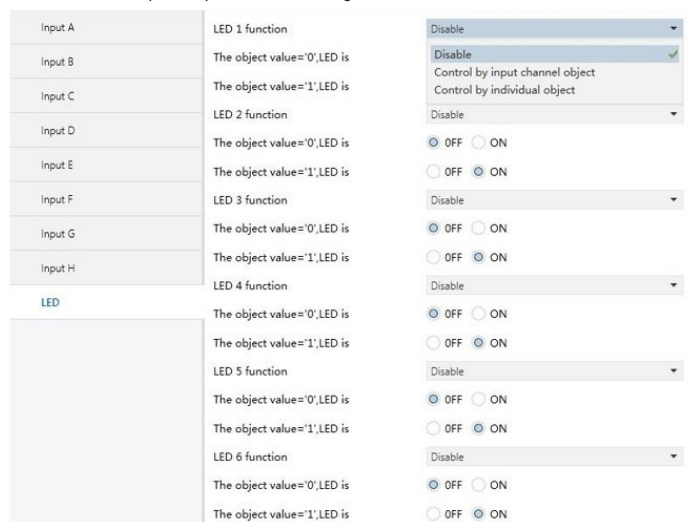

Fig.3.7. Parameter setting window “LED”

“LED X function”

Options:
 Disable
 Control by input channel object
 Control by individual object “Disable”

“Control by input channel object”, the LED is switched on and off according to the value of the switching object of the input function. For the switching function,it is determined by the object “Switch” and for the dimming function, it is determined by “Short, Switch”. Other functions cannot control the LEDs. “Control by individual object”, When this option is selected, the LEDs can be controlled independently of the input function.



“The object value = 0/1, LED is”

This parameter is visible when the previous parameter options is “Control by individual object”, and it is for setting whether the LED will light up or go out when the object of the LED receives a telegram value “1” or “0”.

Options:

- OFF
- ON

Remark:

The setting value of this parameter needs to be adjusted according to the specific LED wiring method.

On common anode wiring, the parameter for the value of the telegram received by the LED object should be set to

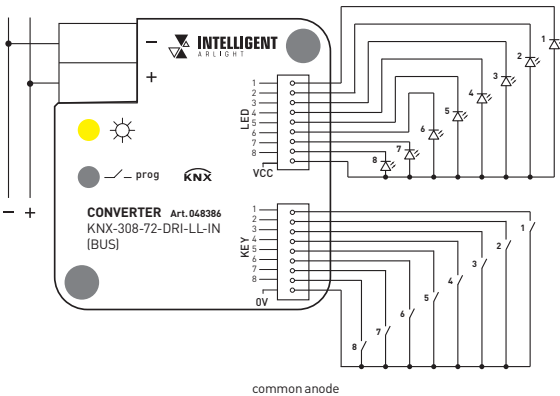

The object value = “0”, LED is ON
The object value = “1”, LED is OFF

On common cathode wiring, the parameter for the value of the telegram received by the LED object should be set:

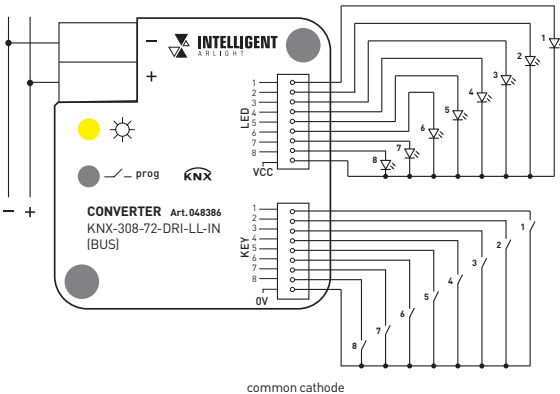

The object value = “0”, LED is OFF
The object value = “1”, LED is ON

4. DESCRIPTION OF COMMUNICATION OBJECT

A communication object is the medium through which a device communicates with other devices on the bus, i.e., only a communication object can communicate on the bus. The role of each communication object is described in detail below.

Note: In the following,

“C” in the attribute column of the table means that the communication function of the communication object is enabled,

“W” means that the value of the communication object can be rewritten via the bus,

“R” means that the value of the communication object can be read via the bus,

“T” means that the value of the communication object has the function of transmission, and “U” means that the value of the communication object can be updated.

4.1. “INPUT X” COMMUNICATION OBJECT

Number	Name	Object Function	Description	Group Address	Length	C	R	W	T	U	Data Type	Priority
0	Input A	Switch			1 bit	C	-	W	T	-		Low
1	Input A	Switch-long			1 bit	C	-	W	T	-		Low
2	Input A	Disable, A			1 bit	C	-	W	-	-		Low

“Switch”

Number	Name	Object Function	Description	Group Address	Length	C	R	W	T	U	Data Type	Priority
0	Input A	Short, Switch			1 bit	C	-	W	T	-		Low
1	Input A	Long, Dimming			4 bit	C	-	W	T	-		Low
2	Input A	Disable, A			1 bit	C	-	W	-	-		Low

“Switch/dimming”

Number	Name	Object Function	Description	Group Address	Length	C	R	W	T	U	Data Type	Priority
0	Input A	Short/Close, 1bit value			1 bit	C	-	-	T	-		Low
1	Input A	Long/Open, 1bit value			1 bit	C	-	-	T	-		Low
2	Input A	Disable, A			1 bit	C	-	W	-	-		Low

“Value/Force output”

Number	Name	Object Function	Description	Group Address	Length	C	R	W	T	U	Data Type	Priority
0	Input A	Short/Close, scene			1 byte	C	-	-	T	-		Low
1	Input A	Long/Open, scene			1 byte	C	-	-	T	-		Low
2	Input A	Disable, A			1 bit	C	-	W	-	-		Low

“Scene control”

Number	Name	Object Function	Description	Group Address	Length	C	R	W	T	U	Data Type	Priority
0	Input A	Up/Down, Blind			1 bit	C	-	-	T	-		Low
1	Input A	Stop/Adjust, Blind			1 bit	C	-	-	T	-		Low
2	Input A	Disable, A			1 bit	C	-	W	-	-		Low

“Shutter control”

Number	Name	Object Function	Description	Group Address	Length	C	R	W	T	U	Data Type	Priority
0	Input A	Register value			1 byte	C	-	-	T	-		Low
2	Input A	Disable, A			1 bit	C	-	W	-	-		Low

“Shift register”

Fig. 4.1 “Input X”

No.	Function	Communication Object	Type	Character	DPT
0	Switch	Input X	1bit	C,W, T	1.001 DPT_Switch
1	Switch-long	Input X	1bit	C,W, T	1.001 DPT_Switch
0	Short, Switch	Input X	1bit	C,W, T	1.001 DPT_Switch
This communication object is used to trigger switching operations. Telegram: 0 – Off 1 – Open					
1	Long, Dimming	Input X	4bit	C,W, T	3.007 DPT_Dimming control
This communication object triggers a relative dimming operation. When the telegram value is 1-7, it is downward dimming, the larger the value in this range, the smaller the downward dimming amplitude is, the largest downward dimming amplitude is when it is 1, the smallest when it is 7, and 0 is to stop dimming; when the input value is 9-15, it is upward dimming, the larger the value in this range, the smaller the upward dimming amplitude is, the largest upward dimming amplitude is when it is 9, the smallest upward dimming amplitude is when it is 15, and 8 is to stop dimming.					
0	Short/Close, 1bit / 4bit / 1byte / 2byte value	Input X	1bit / 4bit / 1byte / 2byte	C,T	1.001 DPT_Switch / 3.007 DPT_Dimming control / 5.010 DPT_counter pulses / 7.001 DPT_pulses
1	Long/Open, 1bit / 4bit / 1byte / 2byte value	Input X	1bit / 4bit / 1byte / 2byte	C,T	
This communication object is used to send contact input values. The range of values that can be sent is determined by the data type, which is set by the parameter “Reaction on short operation or closing the contact” / “Reaction on long operation or opening the contact”.					



No.	Function	Communication Object	Type	Character	DPT
0	Short/Close, Scene	Input X	1byte	C,T	18.001 DPT_Scene Control
1	Long/Open, Scene	Input X	1byte	C,T	18.001 DPT_Scene Control
<p>This communication object is used to send an 8bit instruction to call or store a scene. The following describes the meaning of the 8bit instruction in detail. Let an 8bit instruction be (binary code): FXNNNNNNNN</p> <p>F: a '0' calls the scene; a '1' stores the scene; X:0; NNNNNN: Scene number [0..63]</p> <p>The parameter setting option is 1-64, in fact, the scene message received by communication object "Scene" corresponds to 0-63. For example, if the parameter setting is "Scene 1", the communication object "Scene" receives scene 0. The figure below shows that the communication object "Scene" receives scene 0:</p>					
		The telegram value of the object	Description		
		0	invocation scenario 1		
		1	invocation scenario 2		
		2	invocation scenario 3		
			
		63	invocation scenario 64		
		128	Storage Scenarios 1		
		129	Storage Scenarios 2		
		130	Storage Scenarios 3		
			
		191	Storage Scenarios 64		
0	Up/Down,Blind	Input X	1bit	C,T	1.008DPT_up/down
<p>This communication object is used to move curtains up/down. Telegram: 0 — move up curtains/blinds 1 — move down curtains/blinds</p>					
1	Stop/Adjust, Blind	Input X	1bit	C,T	1.007DPT_Step
<p>This communication object is used to stop the operation of curtains or to adjust the angle of blinds.</p>					
0	Register value	Input X	1bit	C,T	5.010 DPT_counter pulses
<p>This communication object is used to send the value of the shift register.</p>					
2	Disable	Input X	1bit	C,W	1.003DPT_enable
<p>This communication object is used to disable/enable the function of the input channels</p>					

Form 4.1 Communication object "Input X"

Number	Name	Object Function	Description	Group Address	Length	C	R	W	T	U	Data Type	Priority
#24	LED 1	Status			1 bit	C	-	W	-	-		Low
#25	LED 2	Status			1 bit	C	-	W	-	-		Low
#26	LED 3	Status			1 bit	C	-	W	-	-		Low
#27	LED 4	Status			1 bit	C	-	W	-	-		Low
#28	LED 5	Status			1 bit	C	-	W	-	-		Low
#29	LED 6	Status			1 bit	C	-	W	-	-		Low
#30	LED 7	Status			1 bit	C	-	W	-	-		Low
#31	LED 8	Status			1 bit	C	-	W	-	-		Low

4.2. "LED" COMMUNICATION OBJECT

Number	Function	Communication object	Type	Attributes	DPT
24..31	LED X	LED X	1bit	C,W	1.001 DPT_Switch
<p>This communication object is used to receive 1bit type messages for switching instructions.</p>					

Form 4.2 Communication Object "LED"

